

Vented Condensate Pump Package

with Flash Steam Heat Recovery (Steam Pressure-Powered)

The Model VCP-1.5C, Vented Condensate Pump Package with Flash Steam Heat Recovery, is a manufactured, ready-to-install system featuring significant energy savings. Flash Steam is released when trapped Condensate is discharged to atmospheric pressure. The heat available in the Flash Steam is transferred to Make-up Water, or another fluid medium, where heat is required. The result is substantial savings in energy costs at attractive pay-back periods. Also, designed for efficient pumping of condensate, VCP-1.5C utilizes steam power in lieu of electric motors, eliminating the need for wiring motors, starters, and controls. The steam-powered pump package is capable of operation in flammable environments. Operating by steam pressure versus electric power, reduces pumping costs. The pump employs a float operated snap-acting mechanism with no external seals or packing, which eliminates seal maintenance, which is required in conventional pumps. All internal pump components and mechanism are constructed of Stainless Steel

MODEL VCP-1.5C SAVINGS

System Steam Pressure (psig)	Energy Savings (MM Btu/yr.)	Potential Savings (\$/yr.)	Makeup Water side Flow rate (gpm)
125	6,150.11	30,750.55	18.3
100	5,364.24	26,821.18	16.0
80	4,604.52	23,022.58	13.7
60	3,715.49	18,577.44	11.0
40	2,694.71	13,473.53	8.0
30	2,160.85	10,804.25	6.4
20	1,477.23	7,386.16	4.4
15	1,091.83	5,459.16	3.2
10	708.88	3,544.38	2.1
5	332.44	1,662.19	1.0

NOTES:

- Savings are based on max. potential savings at max. pump capacity on 8400 hr./yr. of continuous operation
- Steam costs at \$5.00/MM Btu
- Savings assume no back pressure on Vented Flash Steam.
- Water side flow rate based on at 80°F temperature change from 60°F to 140°F.
- Savings based on approx. calculations.

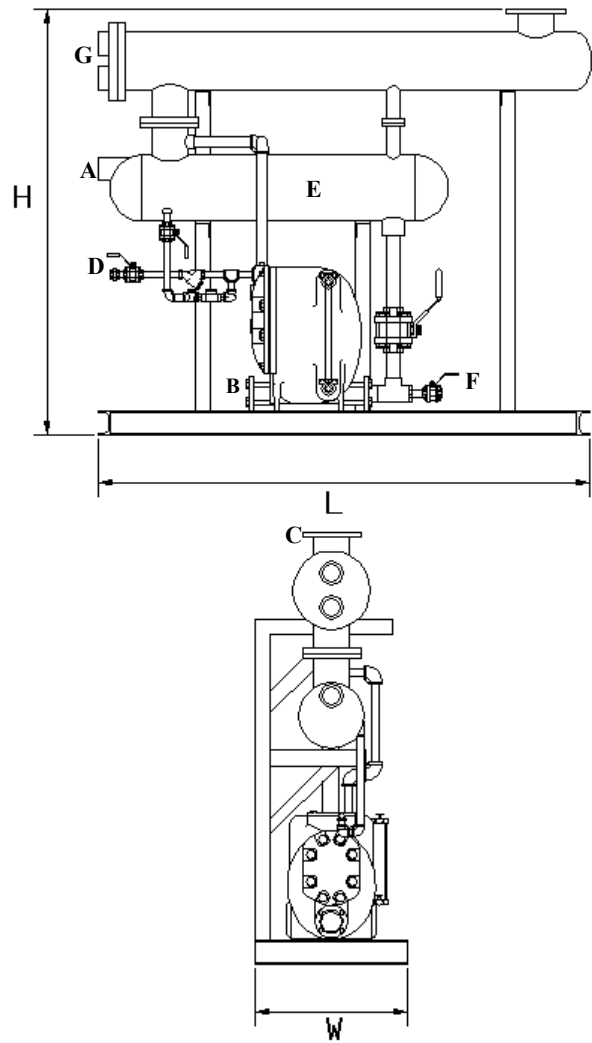

Legend:

- Approximate Dimensions: 56"H x 66"L x 24"W
- A. Condensate Inlet 2" NPT
 - B. Condensate Discharge 1 1/2" NPT
 - C. Vent 3" FLG
 - D. Steam Inlet 1/2" NPT
 - E. Receiver Tank 8"x36"
 - F. Drain 1/2" NPT
 - G. Make-up Water Inlet/Outlet 2" NPT

EnviroSep • Fluid & Heat Recovery Systems
A Division of TMT, Inc.
PO Box 857 • Georgetown, SC 29442
Phone (843) 546-7400 / Fax (843) 546-7407
www.envirosep.com

CONDITIONS OF OPERATION

Max. Allowable Pressure / Temperature:	125 psig / 450 °F
Discharge rate per cycle:	4 gal.
Max. instantaneous discharge rate:	30 gpm
Steam Consumption:	3 lbs. per 1000 lbs. of liquid pumped
Compressed Air Consumption:	100 SCF per 1000 lbs. of liquid pumped

MODEL VCP-1.5C CAPACITIES

Steam Pressure (psig)	Discharge Head (psig)	Flow Rate (lbs. / hr.)
125	15	5,100
125	40	4,500
125	60	4,050
125	80	3,100
125	100	2,650
125	115	1,900
100	15	4,950
100	40	4,000
100	60	3,250
100	80	2,500
75	15	4,800
75	40	3,300
75	60	2,450
50	10	4,400
50	25	3,350
50	40	2,100
25	5	4,000
25	10	3,800
25	15	3,300
10	2	3,000
10	5	2,600
5	2	2,400

Regardless of system size, temperature, pressure, fluid medium, or available floor space, **EnviroSep** can service all specialized needs.

STANDARD CONSTRUCTION

- Fabricated Angle Iron Frame
- Fabricated Steel Tank
- Bronze Ball Valves
- Stainless Steel Thermodynamic Steam Trap
- Cast Iron Pump with Gauge Glass, and Stainless Steel internal components and Check Valves
- Hydrostatically Tested
- High Temperature Industrial Enamel Paint

PACKAGE OPTIONS

- Additional / Oversized Condensate Inlet connection(s)
- Oversized Condensate Receiver
- Oversized Atmospheric Vent(s)
- Carbon Steel 3-piece Ball Valves
- Forged Steel Gate Valves
- Digital Cycle Counter to monitor pumping cycles
- Overflow Connection
- Re-circulating Pump
- Pressure / Temperature Relief Valve
- Low-profile design for height restricted applications
- All Welded piping
- Fabricated Square Tubing Frame
- Flash Steam Heat Recovery System only without Condensate Inlet for Flash Recovery from existing Atmospheric Tanks.

EnviroSep • Fluid & Heat Recovery Systems

A Division of TMT, Inc.

PO Box 857 • Georgetown, SC 29442

Phone (843) 546-7400 / Fax (843) 546-7407

www.envirosep.com