

**Boiler Blowdown Separator
 with Vent Head & Cooling Valve
 Model BDS**

The Model **BDS**, Boiler Blowdown Separator is a manufactured unit used for after-cooling of boiler blowdown or condensate before discharge to Sanitary Sewer. The **BDS** is ideally suited for reducing wastewater temperature of continuous blowdown discharge to municipal sewers. Atmospherically vented, the Model **BDS** is a complete unit including a Carbon Steel Separator, a Make-up Water Capillary-style Temperature Control Valve, and Vent Head. Each Unit is custom engineered and designed to meet specific system requirements. All systems are fabricated and welded per ASME Section IX Code and Standards, and are Hydrostatically tested prior to shipment.

SIZING AND SELECTION

Units are custom engineered for individual systems, based upon the selection of the system parameters:

- I. System Flow Rate: Range of 5 lb/hr to 30,000 lb/hr
- II. Blow-down Upstream Pressure: Range of 5 psig to 250 psig
- III. Flash Vessel Pressure: Range of 0 psig to 15psig
- IV. Dimensions: Based on specific requirements

CONDITIONS OF OPERATION

Max. Allowable Pressure:	125 psig / 8.6 bar
Max. Allowable Temperature:	375 °F / 190.5 °C

Regardless of system size, temperature, pressure, fluid medium, or available floor space,

EnviroSep can service all specialized needs.

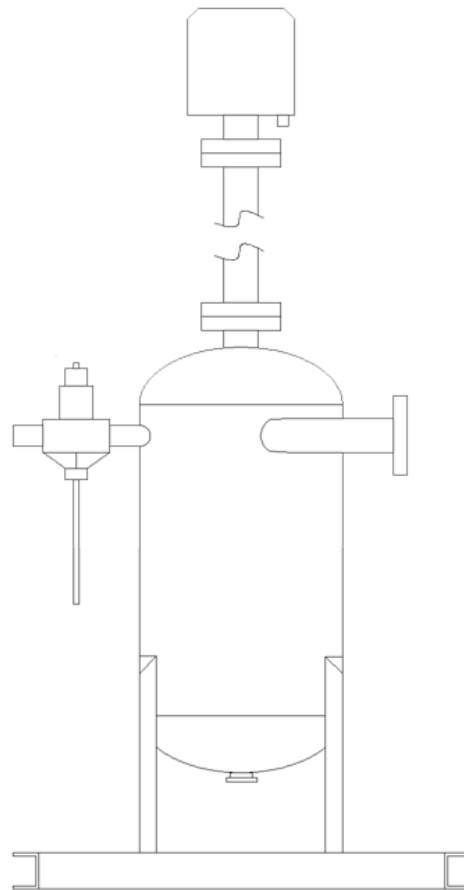

Legend:

- A. Carbon Steel Receiver
- B. Vent Head
- C. Make-up Water Inlet
- D. Capillary-style Temperature Control Valve
- E. Blowdown Inlet
- F. Blended Discharge

STANDARD CONSTRUCTION

- Fabricated Structural Steel Frame
- Capillary-style Temperature Control Valve
- Carbon Steel Flash Vessel
- Hydrostatically Tested
- High Temperature Industrial Enamel Paint

PACKAGE OPTIONS

- System Inlet / Outlet Thermometers
- Stainless Steel Construction
- Oversized Connections